



H-100



Hyundai Motor Company
worldwide.hyundai.com
GEN. LHD 1612 ENG. WD-KM
Copyright © 2016 Hyundai Motor Company. All Rights Reserved.



Your dependable business partner



You demand a lot from your truck and for good reasons: Your customers expect the job to be on budget and on time. So no matter how tough the conditions, the H-100 delivers 100 percent of the time.

A truck to trust

Driven by a passion for excellence, Hyundai has been engineering and manufacturing commercial vehicles for fifty years and satisfying the high expectations of truck owners everywhere.

Professional

Sleek and modern, the H-100 is a real beauty. But it's also a beast thanks to its powerful engine and ruggedly built ladder frame. When it comes to handling the bigger jobs, the H-100 proves more than capable but it also takes on the smaller ones with marvellous efficiency.





Nice job

Purpose-built for the small business owner, the H-100 is a reliable and versatile performer that will help improve your bottom line. Designed to operate under the toughest of conditions, the H-100 is the confident choice of professionals.

Effortless



Total control

Driving perfection begins with the perfect seat position, clear lines of sight in all directions and the logical, intuitive layout of the instruments and controls. The cabin is simply a masterpiece of intelligent design.



5 | 6 Speed manual transmission

The 5-speed transmission is mated to the 2.6 engine while the 6-speed is paired with the 2.5. Both gearboxes are Hyundai-made and are renowned for their efficiency and exceptional durability. Clutch take-up is very smooth and progressive.

01_Audio system The optional audio system includes an AM/FM radio, CD/MP3 player, AUX-USB inputs and door-mounted tweeters for optimal sound fidelity. All models are equipped with a pair of door-mounted speakers.

02_Cluster The instrument panel layout is simple but modern and a pure pleasure to use. Gauges are extra large and easy-to-read, day or night. The standard equipment package includes an LCD odometer and trip computer.

03_Air conditioning system Climate controls feature enhanced functionality courtesy of new, push button-type electric switches that deliver a much more precise feel. And they are backlit for easier nighttime operation.



01



02



03

Advantages

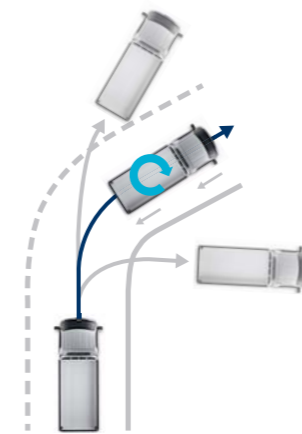

Electronic stability control (ESC)
The optional Electronic Stability Control (ESC) helps you maintain directional control particularly when braking hard on slippery road surfaces. (*Available in select markets and on some models only. Kindly consult with your local Hyundai dealer.)

01_2.5 CRDi diesel engine The clean-running 2.5 diesel features dual overhead camshafts and a common rail diesel injectors and delivers 130PS @ 3,800rpm.

02_2.6 diesel engine The naturally aspirated 2.6 diesel employs single overhead cams and delivers 80PS @ 4,000rpm and 17kg-m of torque at 2,200rpm.

Depend on it

H-100 powertrains are tried and true. Day in and day out, these workhorses are designed to work around the clock, seven days a week with a minimum of preventive maintenance requirements. The H-100: a truck you can truly depend on.



01



02

Diversity

The H-100 is a versatile performer, designed to meet a multitude of transport challenges and is available in variety of configurations. Each model offers a unique combination of crew and cargo carrying capacity. So, whichever model you decide is right for you, you can always choose with confidence.

Unit : mm

Long wheel base standard cab
(Low type rear deck)



Long wheel base double cab
(Low type rear deck)



Long wheel base standard cab
(High type rear deck)

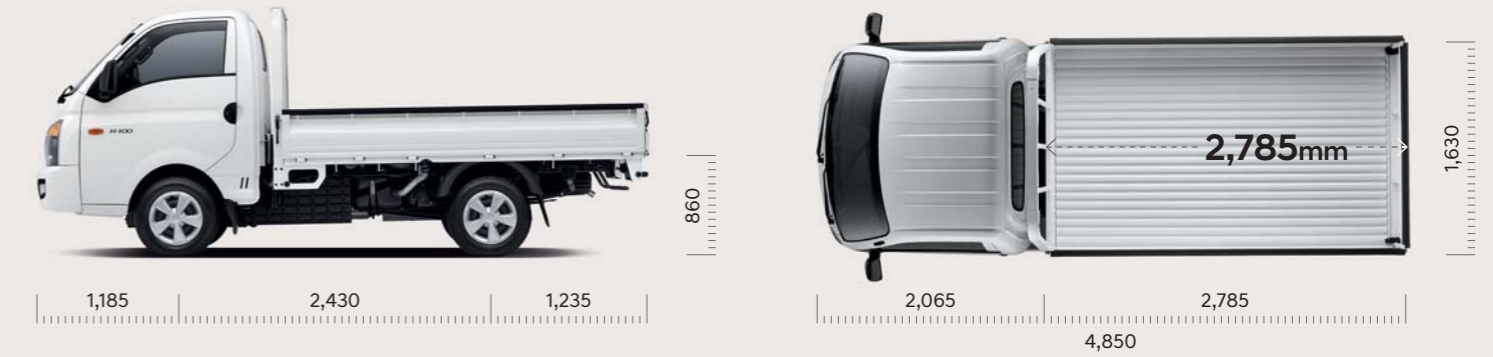

Extra long wheel base standard cab
(Low type rear deck)



Extra long wheel base super cab
(Low type rear deck)

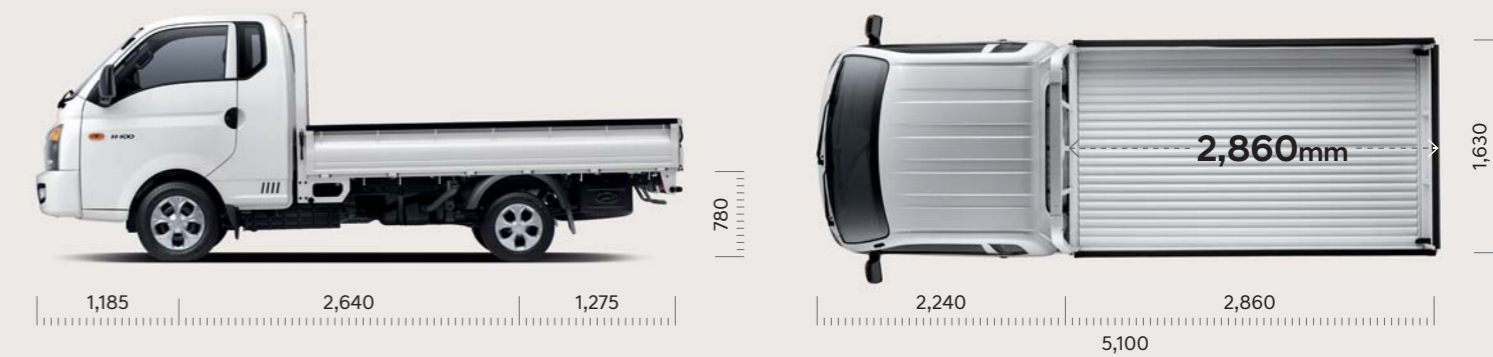

Features



Hood
Power window controls



Side step



Tool-box
Brim cover & tailgate bolt



Wide view outside mirror
Bottle storage & door map pocket



Glove box
Room lamp & sunglass holder



Colors

Exterior

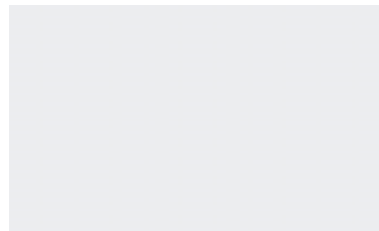

Noble white OA



Onyx blue ZA

Interior



Gray leather



Beige cloth

Wheels



15" Steel wheels

Specifications

* Super cab extra-long wheel base is available only with 2.6 engine

Type		Low deck		High deck		
Cab		Standard / Super / Double		Standard		
Engine		2.6 diesel (Natural aspiration)	2.5 diesel (CRDi)	2.6 diesel (Natural aspiration)	2.5 diesel (CRDi)	
Displacement (cc)		2,607	2,497	2,607	2,497	
Bore x stroke (mm)		91.1 x 100	91 x 96	91.1 x 100	91 x 96	
Compression ratio		22.0 : 1	16.4 : 1	22.0 : 1	16.4 : 1	
Max.Power (PS / rpm)		80 / 4,000	130 / 3,800	80 / 4,000	130 / 3,800	
Max.Torque (kg-m / rpm)		17 / 2,200	26 / 1,500-3,500	17 / 2,200	26 / 1,500-3,500	
Transmission		Manual				
		5-Speed	6-Speed	5-Speed	6-Speed	
Clutch		Dry type with single friction plate				
		Disc. facing diameter (Outside x Thickness)	240 x 8.8	254 x 8.7	240 x 8.8	254 x 8.7
Wheel & tire		Steel				
		Wheel type				
		Wheel size		Front 5.5J x 15"	6.0J x 15"	
				Rear 4.0J x 13"	6.0J x 15"	
Tire size		Front 195 / 70R15C-8PR	195 / 70R15C-8PR			
		Rear 145R13C-8PR	195 / 70R15C-8PR			
Spare tire		Full-size 2ea		Full-size 1ea		

- Some of the equipment illustrated or described in this catalog may not be supplied as standard equipment and may be available at extra cost.
- Hyundai Motor Company reserves the right to change specifications and equipment without prior notice.
- The color plates shown may vary slightly from the actual colors due to the limitations of the printing process.
- Please consult your dealer for full information and availability on colors and trims.



1,485
1,740



2,640
5,175



1,970
780



1,320

* Above dimensions are based on standard cab extra-long wheelbase pictured here

Unit : mm